



## Code Compliance Research Report

## CCRR-0121

Subject to Renewal: 09/02/2012  
Visit [www.ati-es.com](http://www.ati-es.com) for current status

Issued: 09/02/2011  
Revised: 12/09/2011  
Page 1 of 29

**SYNTHEON Inc.**  
**1555 Coraopolis Heights Road**  
**Moon Township, Pennsylvania 15108**  
**(412) 490-5094**  
[www.syntheoninc.com](http://www.syntheoninc.com)

3.2 Uses - **accel-E®** S.T.E.P. Wall System Panels are used for load bearing and non-load bearing, exterior and interior wall panels. 8 inch and 5-1/2" panels are used in all construction types and use groups under the IBC. The 5-1/2" EXT panels are limited to use in Residential One- And Two-Family Dwellings regulated by the IRC.

### 1. Subject

**accel-E®** Steel Thermal Efficient Panel (S.T.E.P.) Wall System

3.3 Steel studs are manufactured from 0.038 inch thick Structural Grade 40 and 0.054 inch thick Structural Grade 55 steel in accordance with ASTM A 1003/A1003M Type H. The 0.038 inch steel is cold-formed to an overall thickness of 0.081 inches with the proprietary UltraSTEEL® process. The EPS density is 1.5 pounds per cubic foot (pcf). The section of stud on the 8 inch thick panel fused with EPS has three rows of perforated slots each 0.787 in x 4 inch and the 5-1/2 inch stud has two rows of perforated slots with the same dimensions. The open cavity side of the stud has knockouts spaced 12 inches from the ends and 24 inches through the center. All stud flanges are 1-5/8 inch with 1/2 inch stiffeners. The EPS ends of the panels are tongue and grooved to allow adjacent panels to interlock. Panels are capped with 18 gauge (0.038 inch) 33 ksi track for accel-E® 38 Walls and 16 gauge (0.054 inch) 50 ksi track for accel-E® 54 Walls. #10 x 3/4 inch self-drilling screws are used to fasten track to steel studs. The 5-1/2 inch EXT panel utilizes the same 5-1/2 inch stud and track as the 5-1/2 inch wall.

### 2. Research Scope

#### 2.1 Building Codes:

- 2006 International Building Code (IBC)
- 2006 International Residential Code (IRC)
- 2006 International Energy Conservation Code (IECC), Section 502 – Building Envelope
- 2009 International Building Code (IBC)
- 2009 International Residential Code (IRC)
- 2009 International Energy Conservation Code (IECC), Section 502 – Building Envelope
- 2007 Florida Building Code (FBC) including High Velocity Hurricane Zone (HVHZ)  
(See Section 3.7 for limitations)

#### 2.2 Properties:

- Structural Performance
- Fire Resistance
- Acoustical Performance
- Thermal Performance

### 3. Description

3.1 General – **accel-E®** S.T.E.P. Wall System Panels are composed of cold-formed steel studs fused to expanded polystyrene (EPS). Each 4-ft. wide panel consists of two (2) parallel "S" shaped studs spaced 24 inch on center (OC). Panels are produced in three thicknesses: 8 inch, 5-1/2 inch and 5-1/2 inch EXT. The 5-1/2" EXT has an additional 1/2" of EPS foam insulation beyond the face of the stud giving the panel an overall thickness of 6 inches.

3.4 Sheathed Shear Walls – Sheathed shear walls recognized in this report are constructed with 1/2" gypsum wallboard meeting ASTM C36 attached to the interior face with #6 x 1-1/4 inch self-drilling screws and 7/16" OSB sheathing attached to the exterior face with #8 x 1-1/2 inch hex-head self-drilling screws. Gypsum and OSB panels are oriented parallel with the studs. Vertical joints align with wall studs and horizontal joints are unblocked. All panel joints are staggered.

3.4.1 Gypsum wallboard shall comply with ASTM C36 – Specification For Gypsum Wallboard

3.4.2 OSB shall be 7/16" rated sheathing in compliance with U.S. Department of Commerce (DOC) product standard PS-2

3.5 X-Braced Shear Walls are braced frames consisting of 16 gauge [50 ksi] steel studs for chord members located in the open (interior) cavity of the wall panel, X-braced with 4 inch or 6 inch wide steel strap as follows:

3.5.1 **accel-E®-38** S.T.E.P. Wall Panels: Four inch wide X-bracing is 16 gauge, 50 ksi. galvanized steel strap attached on the interior face. Steel strap braces are attached at opposing corners of the braced wall segment to 6 inch x 6 inch 12 gauge, 50 ksi gusset plates with a minimum of (12) #10 x 3/4 inch self-drilling screws per plate. Gusset plates are attached to the track and 16 ga. chord studs with (11) #10 x 3/4 inch self-drilling screws. Chord studs are 2.5"x2.5" (AISI 250S250-54) for 5-1/2" and 5-1/2" EXT wall panels and 3-5/8" x 3" 16ga Dietrich HDS studs for 8 inch wall panels. Simpson Strong-Tie S/HTT14 holdown anchors are attached to both chord members with (16) #10 x 3/4" hex head self-drilling screws. See figure 6.

3.5.2 Eight inch **accel-E®-54** S.T.E.P. Wall Panels: Six inch wide X-bracing is 12 gauge, 50 ksi. galvanized steel strap attached on the interior face. Steel strap braces are attached at opposing corners of the braced wall segment to 6"x3"Dietrich 16 ga. HDS studs with (14) #10 x 1" pan head self-drilling screws and (7) #10 x 1" pan head self-drilling screws attached to the track. Simpson Strong-Tie S/HD10S holdown anchors are attached to both chord members with (22) #14 x 1" hex head self-drilling screws. See Figure 7.

3.6 Fire Rated wall panels are constructed with 5-1/2" and 8" **accel-E®** S.T.E.P. Wall System Panels sheathed on each face with 5/8" Type-X gypsum wallboard. Gypsum wallboard is attached with #6 x 1-1/4" self-drilling drywall screws. Fire rated walls are constructed with and without 2-1/2 lb. density mineral wool insulation in the wall cavity. See Tables 11 and 12 for additional details.

3.7 Florida Building Code Systems:

3.7.1 HVHZ System - 8" **accel-E®-38** S.T.E.P. Wall System sheathed with 5/8" 5-ply plywood with face-grain running perpendicular to the studs and fastened with #8 x 1-1/4" self-drilling flat head screws located at each corner and spaced 6" on-center around the perimeter and 12" on-center in the field. See Figure 8 for additional details.

3.7.2 Non-HVHZ System – 5-1/2" and 8" **accel-E®-38** S.T.E.P. Wall Systems are recognized for use in non-windborne debris regions (HVHZ excluded) when installed according to the load span tables and assemblies outlined in this report.

#### 4. Performance

**accel-E®** S.T.E.P. Wall System Panels can be used in load bearing and non-load bearing wall applications and provide the following performance values:

4.1 Allowable structural design properties for strength and flexural stiffness are provided in Table-1. Maximum allowable design loads for wind and, combined axial and wind loading are determined according to Section 2210.4 of the IBC or FBC and AISI/COFS/WSD-2004. Allowable design loads are provided in Tables 2 through 10. Axial loads can be any combination of live load, snow load, and dead loads. All values are for the loading conditions indicated and no adjustments are permitted.

4.1.1 AISI S100-07 reviewed and deemed equivalent for compliance with IBC-09, Section 2210.4.

4.2 Flame Spread & Smoke Development Performance - Expanded Polystyrene (EPS) foam used in the **accel-E®** S.T.E.P. Wall System has a flame spread index not exceeding 25 and a smoke-development index not exceeding 450, as required for EPS in concealed spaces in all types of construction in accordance with Section 719.2 of the IBC.

4.3 Water Vapor Transmission Performance - Expanded Polystyrene (EPS) foam used in the **accel-E®** S.T.E.P. Wall System has a water vapor transmission permeance rating of 0.632 perms at a thickness of 4-3/8 inch and a permeance rating of 0.796 perms at a thickness of 2-5/8 inch when tested in accordance with ASTM E 96.

4.4 Self & Flash Ignition Performance - Expanded Polystyrene (EPS) foam used in the **accel-E®** S.T.E.P. Wall System has a self ignition rating of 480 °C (896 °F) and a flash ignition temperature of 380 °C (716 °F) when tested in accordance with ASTM D 1929.

4.5 Fire rated wall assemblies described in this report achieve a 1-hour fire rating in accordance with ASTM E 119 and may be used for interior or exterior non-load or load bearing walls where a 1-hour fire rated assembly is required. Description of fire rated assemblies is provided in Tables 11 & 12.

4.6 Fire propagation characteristics of some **accel-E®** S.T.E.P. exterior non-load bearing wall assemblies satisfy the conditions of acceptance in accordance with NFPA 285 as required for exterior walls of Type I, II, III or IV of any height in accordance with IBC Section 2603.5.5. See Tables 11 and 12 for wall assemblies identified to comply with NFPA 285.

4.7 Acoustical Performance – When constructed as described in Tables 11 and 12, the **accel-E®** S.T.E.P. Wall System Panel provides the Sound Transmission Class (STC) required for air-borne sound according to Section 1207.2 of the IBC and Section AK102 of the IRC.

4.8 The **accel-E®** S.T.E.P. Wall System Panels have Thermal Resistance (R) and a Thermal Transmittance (U) values shown in Table 13 when tested according to ASTM C 1363-05.

4.9 **accel-E®** S.T.E.P. Wall System Panels exhibit an air infiltration rate < 0.01 cfm per square foot at a test pressure of 6.27 pounds per square foot when tested according to ASTM E 283-04.

## 5. Installation

Installation shall be in accordance with the applicable code, manufacturer's installation instructions and this report. Where differences occur between this report and the manufacturer's installation instructions, this report shall govern.

5.1 Load bearing studs shall be aligned vertically with other framing members (joists, rafters, trusses, etc.) in compliance with AISI/COFS/GP-2004 Section C1 for the IBC and Section R603.1.2 of the IRC.

5.2 **accel-E®** S.T.E.P. Wall System Panels used in exterior wall applications shall be covered with an approved exterior wall covering in accordance with IBC Chapter 14. Exterior veneers that require structural support for design wind pressures must be installed with an approved structural sheathing and shall include a water resistive barrier complying with IBC or FBC Section 1404.2

5.3 EPS foam shall be separated from the interior of the building by an approved thermal barrier in accordance with Section 2603.4 of the IBC.

5.4 Wall cavities shall be fire blocked in accordance with the requirements in Section 717 of the IBC.

## 6. Supporting Evidence

6.1 Manufacturer's drawings and installation instructions.

6.2 Reports of testing and engineering analysis in accordance with the following codes and standards:

ICC-ES AC46, Acceptance Criteria for Cold-Formed Steel Framing Members, effective July 1, 2010.

Structural performance testing in accordance with ASTM E 72-02 – Standard Tests Methods of Conducting Strength Tests for Panels of Building Construction.

Testing on expanded polystyrene foam in accordance with ASTM E 96-05 – Standard Tests Methods for Water Vapor Transmission of Materials.

Testing on expanded polystyrene foam in accordance with ASTM D 1929-96 – Standard Tests Methods for Determining Ignition Temperature of Plastics.

Calculations for design strengths and determination of allowable design loads signed and sealed by a registered professional engineer.

Fire testing on expanded polystyrene foam in accordance with ASTM E 84-05 - Surface Burning Characteristics of Building Materials.

ASTM E119-07a - Test Methods for Fire Tests of Building Construction and Materials.

NFPA 285 - 2006 Edition Standard Fire Test Method for Evaluation of Fire Propagation Characteristics of Exterior Non-Load-Bearing Wall Assemblies Containing Combustible Components.

NFPA 259 – 98 Standard Test Method for Potential Heat of Building Materials.

Acoustical Testing in accordance with ASTM E90-04 -Testing Standard for Air-Borne Sound Transmission Loss of Building Partitions and Elements.

Air leakage testing in accordance with ASTM E283-04 - Test Method for Determining Rate of Airflow Through Exterior Windows, Curtain Walls, and Doors Under Specified Pressure Differential Across Specimens.

Thermal performance tests in accordance with ASTM C1363-05 - Test Method for Thermal Performance of Building Materials and Envelope Assemblies by Means of a Hot Box.

Impact testing in accordance with TAS 201-94 - Impact Test Procedures.

Static air pressure tests in accordance with TAS 202-94 - Criteria for Testing Impact & Non Impact Resistant Building Envelope Components Using Uniform Static Air Pressure.

Cyclic wind pressure tests in accordance with TAS 203-94 - Criteria for Testing Products Subject to Cyclic Wind Pressure Loading.

6.3 ICC-ES Evaluation Report, ESR-1798 for NOVA Chemicals Inc. Expanded Polystyrene (EPS) Beads recognizing a flame spread index of 25 or less and a smoke development index of 450 or less for EPS products with a density and maximum thickness of 1.5 pcf and 6 inches respectively.

6.4 Quality control manual in compliance with ICC-ES Acceptance Criteria for Quality Control System Documentation, AC10 effective March 1, 2009.

## 7. Conditions of Use

The SYNTHEON Inc. **accel-E®** S.T.E.P. Wall System Panel identified in this report is deemed to comply with the referenced building codes for above grade use subject to the following conditions.

7.1 All designs and calculations shall be prepared by a licensed design professional according to the requirements in the jurisdiction where the project is located.

7.2 Design strengths are derived from values in Table 1.

7.3 Allowable heights and loadings identified in this report shall not be exceeded.

7.4 In load-bearing wall applications, concentrated loads shall not be imposed between studs without additional framing members specified by a design professional.

7.5 Framed wall openings for doors, windows, louvers, etc. are not within the scope of this report and shall be designed and constructed in accordance with applicable AISI standards referenced under Section 2210 of the IBC.

7.6 Shear wall design values for seismic loads presented in Tables 5, 6 & 7 are limited to Seismic Design Category A, B and C. Evaluation for use in Seismic Design Category D, E & F is beyond the scope of this report.

7.7 Jobsite manufacturing of studs or tracks are outside the scope of this report.

7.8 Fire rated wall assemblies recognized in tables 11 thru 13 are tested, listed and labeled by Southwest Research Institute (SwRI) – San Antonio, TX. See SwRI listing for complete details of the rated wall assemblies.

7.8.1 Wall assemblies recognized compliant with NFPA 285 are limited to non-load bearing walls.

7.9 The SYNTHEON Inc. **accel-E®** S.T.E.P Wall Panel System identified in this report is manufactured in accordance with the manufacturer's approved quality control system with inspections by Architectural Testing, Inc (AA-676) in Leetsdale, Pennsylvania.

### **8. Identification**

SYNTHEON Inc. **accel-E®** S.T.E.P Wall Panel System produced in accordance with this report shall be identified with labeling that includes the following information:

8.1 The manufacturers name and/or logo

8.2 The mark of the independent inspection agency, Architectural Testing, Inc. (AA-676)

8.3 The ATI Code Compliance Research Report Number (CCRR-0121)

### **9. Code Compliance Research Report Use**

9.1 Approval of building products and/or materials can only be granted by a building official having legal authority in the specific jurisdiction where approval is sought.

9.2 Code Compliance Research Reports shall not be used in any manner that implies an endorsement of the product or manufacturer by ATI.

9.3 Reference to the Architectural Testing internet web site address at [www.ati-es.com](http://www.ati-es.com) is recommended to ascertain the current version and status of this report.

**Table 1 - accel-E® S.T.E.P. Wall Panel System Design Properties <sup>1,6</sup>**

Panel Size	Flexural <sup>3,4,7</sup>						Axial Compression Strength (lb) <sup>5</sup>
	Positive Bending		Negative Bending		Max. Reaction Load		
	M (kip-in)	EI (E+07)	M (kip-in)	EI (E+07)	End (lb)	Int. (lb) <sup>2</sup>	
5-1/2" x 8' E38 5-1/2" EXT x 8' E38	25.75	7.02	26.24	8.60	1,412	889	6,836
5-1/2" x 12' E38 5-1/2" EXT x 12' E38	25.75	11.4	26.24	11.4	1,412	889	6,836
8" x 8' E38	42.78	14.1	48.86	17.9	1,441	1,052	8,502
8" x 12' E38	42.78	23.6	43.70	22.1	1,441	1,052	8,502
8" x 20' E38	42.78	23.6	43.70	22.1	1,441	1,052	8,502
8" x 8' E54	46.49	16.1	43.29	15.1	2,799	1,736	9,178
8" x 14' E54	59.82	27.4	62.74	28.1	2,799	1,736	7,528
8" x 20' E54	59.82	27.4	62.74	28.1	2,799	1,736	7,528

<sup>1</sup> Values are per wall panel (2 studs / 4-ft. panel)

<sup>2</sup> 1-5/8" bearing length

<sup>3</sup> Flexural values for panels between 8' and 12' /14' may be interpolated.

<sup>4</sup> Flexural values for 12' panels may be used for wall heights up to 24' and 14' panels up to 28' heights.

<sup>5</sup> 8" accel-E® 38 & 54 Load bearing walls are limited to wall heights not exceeding 20' and 5-1/2" accel-E® 38 & 54 & 5-1/2" accel-E® 38 & 54 EXT load bearing walls are limited to wall heights not exceeding 12'.

<sup>6</sup> Safety factor for all design properties were calculated in accordance with Section F1.2 of the AISI/COS/NASPEC 2001. Safety factor for 5-1/2" accel-E® 38 & 54 wall's bending and reaction load is 1.95 and axial compression load is 2.05. Safety factor for 8" accel-E® 38 wall's bending, reaction, and axial compression load is 1.95. Safety factor for 8" accel-E® 54 wall's +8' & ±14' bending, reaction, and 8' axial compression load is 1.95. Safety factor for 8" accel-E® 54 wall's -8' bending is 1.97 and safety factor for 20' axial compression load is 2.28.

<sup>7</sup> Flexural values do not depend upon lateral bracing provided by sheathing on the exterior face (EPS side). Lateral bracing of the interior (cavity side) face is required throughout the length of the stud by application of sheathing fastened no greater than 12"o.c.



Table 2, 3, & 4 - Wind Load Design Tables

1. All allowable loads are based on the limiting strength or stiffness values and safety factors listed in Table 1.
2.  $w_{max}$  equals maximum allowable wind pressure in pounds per square foot (psf).
3. (+) values are maximum positive wind pressure
4. (-) values are maximum negative wind pressure
5.  Denotes pressure limited by stud end reaction capacity.  
 Denotes pressure limited by flexural strength of studs.  
 All other values limited by flexural stiffness (deflection limit)

Table 2 - Wind Load Design Table - 5-1/2" accel-E® 38 and 5-1/2" EXT accel-E® 38 Wall Panels

Wall Hgt. (ft)	DEFLECTION CRITERIA									
	L/120		L/240		L/360		L/600		L/720	
	(+) $w_{max}$	(-) $w_{max}$	(+) $w_{max}$	(-) $w_{max}$	(+) $w_{max}$	(-) $w_{max}$	(+) $w_{max}$	(-) $w_{max}$	(+) $w_{max}$	(-) $w_{max}$
8	44	44	44	44	44	44	30	37	25	31
8.5	42	42	42	42	42	42	27	32	23	27
9	39	39	39	39	39	39	25	28	21	24
9.5	37	37	37	37	37	37	22	25	19	21
10	35	35	35	35	34	35	20	22	17	19
10.5	34	34	34	34	31	33	19	20	16	17
11	32	32	32	32	29	30	17	18	14	15
11.5	31	31	31	31	26	27	16	16	13	13
12	29	29	29	29	24	24	15	15	12	12
12.5	27	27	27	27	22	22	13	13	11	11
13	25	25	25	25	19	19	12	12	-	-
13.5	24	24	24	24	17	17	10	10	-	-
14	22	22	22	22	15	15	-	-	-	-
14.5	20	20	20	20	14	14	-	-	-	-
15	19	19	19	19	13	13	-	-	-	-
15.5	18	18	17	17	11	11	-	-	-	-
16	17	17	15	15	10	10	-	-	-	-
16.5	16	16	14	14	-	-	-	-	-	-
17	15	15	13	13	-	-	-	-	-	-
17.5	14	14	12	12	-	-	-	-	-	-
18	13	13	11	11	-	-	-	-	-	-
18.5	13	13	10	10	-	-	-	-	-	-

**Table 3 - Wind Load Design Tables - 8" accel-E® 38 Wall Panels**

Wall Hgt. (ft)	DEFLECTION CRITERIA									
	L/120		L/240		L/360		L/600		L/720	
	(+) $w_{max}$	(-) $w_{max}$	(+) $w_{max}$	(-) $w_{max}$	(+) $w_{max}$	(-) $w_{max}$	(+) $w_{max}$	(-) $w_{max}$	(+) $w_{max}$	(-) $w_{max}$
8	45	45	45	45	45	45	45	45	45	45
8.5	42	42	42	42	42	42	42	42	42	42
9	40	40	40	40	40	40	40	40	40	40
9.5	38	38	38	38	38	38	38	38	38	38
10	36	36	36	36	36	36	36	36	35	36
10.5	34	34	34	34	34	34	34	34	32	33
11	33	33	33	33	33	33	33	33	30	29
11.5	31	31	31	31	31	31	31	31	27	26
12	30	30	30	30	30	30	30	28	25	24
12.5	29	29	29	29	29	29	27	25	22	21
13	28	28	28	28	28	28	24	22	20	19
13.5	27	27	27	27	27	27	21	20	18	17
14	26	26	26	26	26	26	19	18	16	15
14.5	25	25	25	25	25	25	17	16	14	13
15	24	24	24	24	24	24	16	15	13	12
15.5	23	23	23	23	23	22	14	13	12	11
16	23	23	23	23	21	20	13	12	11	10
16.5	22	22	22	22	19	18	12	11	-	-
17	21	21	21	21	18	17	11	10	-	-
17.5	21	21	21	21	16	15	-	-	-	-
18	20	20	20	20	15	14	-	-	-	-
18.5	20	20	20	19	14	13	-	-	-	-
19	19	19	19	18	13	12	-	-	-	-
19.5	19	19	18	17	12	11	-	-	-	-
20	18	18	16	15	11	10	-	-	-	-
20.5	17	17	15	14	-	-	-	-	-	-
21	16	16	14	13	-	-	-	-	-	-
21.5	15	17	13	12	-	-	-	-	-	-
22	15	16	12	12	-	-	-	-	-	-
22.5	14	15	12	11	-	-	-	-	-	-
23	13	15	11	10	-	-	-	-	-	-



**Table 4 - Wind Load Design Tables - 8" accel-E® 54 Wall Panels**

Wall Hgt. (ft)	DEFLECTION CRITERIA									
	L/120		L/240		L/360		L/600		L/720	
	(+) W <sub>max</sub>	(-) W <sub>max</sub>	(+) W <sub>max</sub>	(-) W <sub>max</sub>	(+) W <sub>max</sub>	(-) W <sub>max</sub>	(+) W <sub>max</sub>	(-) W <sub>max</sub>	(+) W <sub>max</sub>	(-) W <sub>max</sub>
8	88	88	88	88	88	88	70	66	58	55
8.5	82	82	82	82	82	82	62	59	51	49
9	78	78	78	78	78	78	55	53	46	44
9.5	74	74	74	74	74	74	49	48	41	40
10	70	70	70	70	70	70	44	43	37	36
10.5	67	67	67	67	67	66	40	39	33	33
11	64	64	64	64	61	60	36	36	30	30
11.5	61	61	61	61	55	55	33	33	28	28
12	58	58	58	58	51	51	30	31	25	26
12.5	56	56	56	56	47	47	28	28	23	24
13	54	54	54	54	43	44	26	26	22	22
13.5	52	52	52	52	40	41	24	24	20	20
14	50	50	50	50	37	38	22	23	19	19
14.5	47	47	47	47	33	34	20	21	17	17
15	44	47	44	46	30	31	18	19	15	15
15.5	42	44	41	42	27	28	16	17	14	14
16	39	41	37	38	25	25	15	15	12	13
16.5	37	38	34	35	23	23	14	14	11	12
17	35	36	31	32	21	21	12	13	10	11
17.5	33	34	28	29	19	19	11	12	-	-
18	31	32	26	27	17	18	10	11	-	-
18.5	29	31	24	25	16	16	-	-	-	-
19	28	29	22	23	15	15	-	-	-	-
19.5	26	28	21	21	14	14	-	-	-	-
20	25	26	19	20	13	13	-	-	-	-
20.5	24	25	18	18	12	12	-	-	-	-
21	23	24	16	17	11	11	-	-	-	-
21.5	22	23	15	16	10	11	-	-	-	-
22	21	22	14	15	-	-	-	-	-	-
22.5	20	21	13	14	-	-	-	-	-	-
23	19	20	13	13	-	-	-	-	-	-
23.5	18	19	12	12	-	-	-	-	-	-
24	17	18	11	11	-	-	-	-	-	-
24.5	17	17	10	11	-	-	-	-	-	-

**Table 5, 6, & 7 - Shear Wall Design Loads**

1. Allowable loads for sheathed wall panels are pounds per lineal foot of shear wall length.
2. Allowable loads for X-Brace wall panels are pounds per braced wall segment.
3. Maximum aspect ratio (H/L) is the ratio of wall height to wall length.
4. Allowable Seismic loads are limited to Seismic Design Categories A, B and C.

**Table 5 - Shear Wall Design Loads - 5-1/2" accel-E® 38 Wall Panels**

Wall Construction	Max. Aspect Ratio (H/L)	Fastener Spacing		Allowable Shear (Wind) $\Omega_W = 2.0$	Allowable Shear (Seismic) $\Omega_S = 2.5$
		OSB Edge / Field	Gyp. Bd. Edge / Field		
Sheathed Shear Wall Panels: 7/16" Rated OSB on Exterior Face + 1/2" Gypsum Board on Interior Face	2.67	6" / 12"	7" / 12"	340 lb/ft	272 lb/ft
Braced Wall Segment: X-Braced with 4" x 16 Ga. Steel Strap (See Figure 6)	2.00	N/A	N/A	1888 lb	1512 lb

**Table 6 – Shear Wall Design Loads – 5-1/2" EXT accel-E® 38 Wall Panels**

Wall Construction	Max. Aspect Ratio (H/L)	Fastener Spacing		Allowable Shear (Wind) $\Omega_W = 2.0$	Allowable Shear (Seismic) $\Omega_S = 2.5$
		OSB Edge / Field	Gyp. Bd. Edge / Field		
Braced Wall Segment: X-Braced with 4" x 16 Ga. Steel Strap (See Figure 6)	2.00	N/A	N/A	1888 lb	1512 lb

**Table 7 - Shear Wall Design Loads - 8" accel-E® Wall Panels**

Wall Construction	Max. Aspect Ratio (H/L)	Fastener Spacing		Allowable Shear (Wind) $\Omega_W = 2.0$	Allowable Shear (Seismic) $\Omega_S = 2.5$
		OSB Edge / Field	Gyp. Bd. Edge / Field		
E38 Sheathed Shear Wall Panels: 7/16" Rated OSB on Exterior Face + 1/2" Gypsum Board on Interior Face	2.67	6" / 12"	7" / 12"	375 lb/ft	300 lb/ft
E38 Braced Wall Segment: X-Braced with 4" x 16 Ga. Steel Strap (See Figure 6)	2.00	N/A	N/A	2152 lb	1728 lb
E54 Braced Wall Segment: X-Braced with 6" x 12 Ga Steel Strap (See Figure 7)	2.00	N/A	N/A	2,301 lb	1,841 lb

**Table 8 – Allowable Design Loads For Exterior And Interior Load Bearing Walls for 5-1/2" and 5-1/2" EXT accel-E® 38 Wall Panels**

1. Values are total load (lb.) per wall panel (2 studs / 4-ft. panel)
2. Load bearing walls are limited to wall heights not exceeding 12-ft.
3.  $w_{max}$  equals design wind pressure in pounds per square foot (psf). Combined axial/transverse loads have not been multiplied by 0.75 for calculating combined stress.
4. Safety factors have been calculated in accordance with Section F1.2 of the AISI/COS/NASPEC 2001 and are a minimum of 1.95.
5. Safety factors: Flexure = 1.95, Axial Compression = 2.05, End Reaction = 1.95
- 6...   Denotes values w/deflection  $\leq L/240$ ,   Denotes values w/deflection  $\leq L/600$ . All other values meet deflection criteria  $\leq L/360$
7. Design pressures less than 10 psf shall not be used for wind loads (interior use only).

**Table 7 - Load Bearing Wall Tables - 5-1/2" accel-E® 38 and 5-1/2" EXT accel-E® 38 Wall Panels**

Wall Hgt. (ft)	TRANSVERSE LOAD (psf)														
	0 psf	(+) 5 psf	(-) 5 psf	(+) 15 psf	(-) 15 psf	(+) 20 psf	(-) 20 psf	(+) 25 psf	(-) 25 psf	(+) 30 psf	(-) 30 psf	(+) 35 psf	(-) 35 psf	(+) 40 psf	(-) 40 psf
8	6,836	6,318	6,336	5,307	5,335	4,797	4,835	4,287	4,335	3,778	3,835	3,268	3,335	2,758	2,834
8.5	6,836	6,247	6,271	5,110	5,142	4,534	4,577	3,959	4,013	3,383	3,448	2,808	2,883	2,233	2,319
9	6,836	6,171	6,200	4,901	4,937	4,256	4,304	3,610	3,671	2,965	3,038	2,320	2,405	-	-
9.5	6,836	6,090	6,120	4,680	4,720	3,961	4,015	3,242	3,309	2,523	2,604	1,805	1,899	-	-
10	6,836	6,005	6,034	4,447	4,491	3,650	3,710	2,854	2,928	2,057	2,147	1,261	1,365	-	-
10.5	6,836	5,914	5,943	4,202	4,251	3,324	3,389	2,446	2,528	1,568	1,666	-	-	-	-
11	6,836	5,819	5,846	3,945	3,999	2,981	3,053	2,018	2,108	1,054	1,162	-	-	-	-
11.5	6,836	5,719	5,744	3,676	3,735	2,623	2,702	1,570	1,668	516	634	-	-	-	-
12	6,836	5,615	5,636	3,395	3,460	2,249	2,334	1,102	1,209	-	-	-	-	-	-

**Tables 9 & 10 – Allowable Design Loads For Exterior And Interior Load Bearing Walls for 8" accel-E® 38 and accel-E® 54 Wall Panels**

1. Values are total load (lb.) per wall panel (2 studs / 4-ft. panel)
2. Load bearing walls are limited to wall heights not exceeding 20-ft.
3.  $w_{max}$  equals design wind pressure in pounds per square foot (psf). Combined axial/transverse loads have not been multiplied by 0.75 for calculating combined stress.
4. Safety factors have been calculated in accordance with Section F1.2 of the AISI/COS/NASPEC 2001 and are a minimum of 1.95.
5. Safety factors: Flexure = 1.95, Axial Compression = 1.95, End Reaction = 1.95
- 6...   Denotes values w/deflection  $\leq L/240$ ,   Denotes values w/deflection  $\leq L/600$ . All other values meet deflection criteria  $\leq L/360$
7. Design pressures less than 10 psf shall not be used for wind loads (interior use only)

**Table 9 - Load Bearing Wall Tables - 8" accel-E® 38 Wall Panels**

Wall Hgt. (ft)	TRANSVERSE LOAD (psf)																
	0 psf	(+) 5 psf	(-) 5 psf	(+) 15 psf	(-) 15 psf	(+) 20 psf	(-) 20 psf	(+) 25 psf	(-) 25 psf	(+) 30 psf	(-) 30 psf	(+) 35 psf	(-) 35 psf	(+) 40 psf	(-) 40 psf	(+) 45 psf	(-) 45 psf
8	8,502	8,120	8,149	7,357	7,444	6,976	7,091	6,594	6,738	6,213	6,386	5,831	6,033	5,449	5,680	5,068	5,328
8.5	8,502	8,071	8,104	7,210	7,307	6,779	6,909	6,348	6,511	5,917	6,113	5,487	5,715	5,056	5,317	0	0
9	8,502	8,019	8,056	7,053	7,163	6,570	6,716	6,087	6,270	5,604	5,824	5,121	5,377	4,639	4,931	0	0
9.5	8,502	7,964	8,005	6,888	7,010	6,350	6,512	5,812	6,015	5,274	5,518	4,735	5,020	0	0	0	0
10	8,502	7,906	7,951	6,713	6,849	6,117	6,298	5,521	5,746	4,925	5,195	4,329	4,644	0	0	0	0
10.5	8,502	7,845	7,894	6,530	6,679	5,873	6,072	5,215	5,464	4,558	4,856	0	0	0	0	0	0
11	8,502	7,781	7,835	6,338	6,501	5,616	5,835	4,895	5,168	4,173	4,501	0	0	0	0	0	0
11.5	8,502	7,714	7,773	6,137	6,315	5,348	5,587	4,560	4,858	3,771	4,129	0	0	0	0	0	0
12	8,502	7,643	7,708	5,926	6,121	5,068	5,328	4,209	4,534	3,351	3,740	0	0	0	0	0	0
13	8,502	7,491	7,555	5,479	5,708	4,472	4,776	3,464	3,845	0	0	0	0	0	0	0	0
14	8,502	7,302	7,374	4,996	5,261	3,828	4,181	2,659	3,101	0	0	0	0	0	0	0	0
15	8,502	7,091	7,172	4,478	4,782	3,136	3,542	0	0	0	0	0	0	0	0	0	0
16	8,502	6,857	6,947	3,923	4,269	2,397	2,858	0	0	0	0	0	0	0	0	0	0
17	8,502	6,601	6,699	3,333	3,724	1,610	2,131	0	0	0	0	0	0	0	0	0	0
18	8,502	6,322	6,429	2,707	3,145	0	0	0	0	0	0	0	0	0	0	0	0
19	8,502	6,024	6,137	2,045	2,533	0	0	0	0	0	0	0	0	0	0	0	0
20	8,502	5,707	5,827	1,347	1,889	0	0	0	0	0	0	0	0	0	0	0	0

**Table 10 - Load Bearing Wall Tables - 8" accel-E® 54 Wall Panels**

Wall Hgt. (ft)	WIND LOAD PER PANEL																		
	0 psf	(+) 5 psf	(-) 5 psf	(+) 15 psf	(-) 15 psf	(+) 20 psf	(-) 20 psf	(+) 25 psf	(-) 25 psf	(+) 30 psf	(-) 30 psf	(+) 35 psf	(-) 35 psf	(+) 40 psf	(-) 40 psf	(+) 45 psf	(-) 45 psf	(+) 50 psf	(-) 50 psf
8	9,178	8,883	8,897	8,294	8,335	8,000	8,055	7,705	7,774	7,411	7,493	7,116	7,212	6,821	6,931	6,527	6,650	6,232	6,551
8.5	7,528	7,255	7,268	6,710	6,748	6,437	6,488	6,164	6,228	5,891	5,968	5,619	5,707	5,346	5,447	5,073	5,187	4,800	5,095
9	7,528	7,222	7,236	6,611	6,653	6,305	6,362	5,999	6,070	5,693	5,779	5,387	5,487	5,082	5,195	4,776	4,904	4,470	4,801
9.5	7,528	7,187	7,203	6,506	6,553	6,165	6,229	5,824	5,904	5,484	5,579	5,143	5,254	4,802	4,929	4,461	4,604	4,121	4,489
10	7,528	7,150	7,168	6,395	6,448	6,018	6,088	5,640	5,728	5,263	5,368	4,885	5,008	4,508	4,648	4,130	4,288	3,753	4,161
10.5	7,528	7,112	7,131	6,279	6,337	5,863	5,941	5,447	5,544	5,031	5,147	4,614	4,750	4,198	4,353	3,782	3,956	3,366	3,816
11	7,528	7,071	7,092	6,158	6,221	5,701	5,786	5,244	5,350	4,787	4,915	4,330	4,479	3,873	4,044	3,417	3,608	2,960	3,454
11.5	7,528	7,029	7,052	6,030	6,100	5,531	5,624	5,032	5,148	4,532	4,672	4,033	4,196	3,534	3,720	3,034	3,244	2,535	3,075
12	7,528	6,984	7,010	5,897	5,973	5,353	5,455	4,810	4,936	4,266	4,418	3,722	3,900	3,179	3,381	2,635	2,863	2,092	2,679
13	7,528	6,890	6,920	5,614	5,703	4,976	5,095	4,338	4,486	3,700	3,878	3,062	3,270	2,424	2,661	2,395	2,617	1,148	1,837
14	7,528	6,778	6,816	5,308	5,411	4,568	4,706	3,828	4,000	3,088	3,295	2,348	2,589	1,608	1,884	868	1,178	0	0
15	7,528	6,639	6,690	4,980	5,098	4,130	4,288	3,281	3,478	2,431	2,669	1,582	1,859	732	1,049	0	0	0	0
16	7,528	6,503	6,551	4,629	4,763	3,662	3,842	2,696	2,920	1,729	1,999	763	1,077	0	0	0	0	0	0
17	7,528	6,336	6,396	4,255	4,405	3,164	3,367	2,073	2,327	982	1,286	0	0	0	0	0	0	0	0
18	7,528	6,156	6,226	3,852	4,013	2,635	2,863	1,412	1,697	0	0	0	0	0	0	0	0	0	0
19	7,528	5,960	6,039	3,437	3,610	2,076	2,330	0	0	0	0	0	0	0	0	0	0	0	0
20	7,528	5,747	5,837	2,998	3,201	0	0	0	0	0	0	0	0	0	0	0	0	0	0

**Table 11 & 12 - Sound Insulation Properties & Fire Rated Assemblies**

1. Sound Transmission Class (STC) Rating for Interior Air-Bourne Sound.  
 STC value required for compliance with Section 1207.2 of the IBC and Section AK102 of the IRC:  
     STC ≥ 50 for IBC  
     STC ≥ 45 for IRC  
 STC ratings apply to wall panels with E38 studs only.
2. Outdoor to Indoor Sound Transmission Loss (OITC) Rating for Exterior Air-Bourne Sound  
 OITC ratings apply to wall panels with E38 studs only.
3. Fire ratings for fire rated assemblies in accordance with ASTM E 119.  
 Fire Ratings apply to wall panels with E38 and E54 studs, unless noted otherwise.  
 Fire ratings are listed by Southwest Research Institute (SwRI). See SwRI listing complete description of fire rated wall assembly.
4. Non-Load Bearing wall assemblies shown in Tables 11 and 12 meet NFPA 285 condition of acceptance for use in exterior walls of Type I, II, III or IV in accordance with IBC Section 2603.5.5. See Figure 9 for typical installations.

**Table 11 - 5-1/2" accel-E® 38 S.T.E.P. Wall Assemblies**

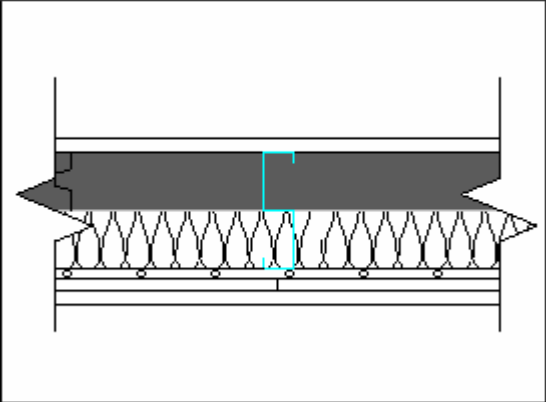
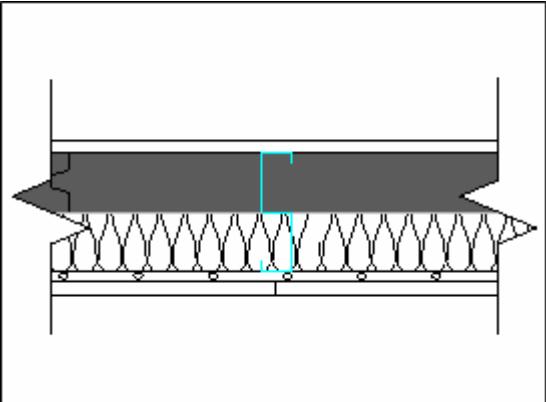
Assembly Description	Section STC	Section OITC	Fire Rating
<b>Non-Load Bearing</b> <ul style="list-style-type: none"> <li>▪ 5/8" Type-X Gypsum Sheathing</li> <li>▪ 5-1/2" accel-E® Panel Studs @ 24" O/C</li> <li>▪ 2" R8.33 Glass Fiber Insulation</li> <li>▪ 25 GA Resilient Channel spaced @ 24" O/C</li> <li>▪ (2) Layers 5/8" Type X Gypsum</li> </ul> <hr/> See Figure 9 for additional NFPA 285 information.	<b>55</b>	<b>37</b>	<b>1-HOUR</b>
			
<b>Non-Load Bearing</b> <ul style="list-style-type: none"> <li>▪ 5/8" Type-X Gypsum Sheathing</li> <li>▪ 5-1/2" accel-E® Panel Studs @ 24" O/C</li> <li>▪ 2" R8.33 Glass Fiber Insulation</li> <li>▪ 25 GA Resilient Channel spaced @ 24" O/C</li> <li>▪ 5/8" Type X Gypsum</li> </ul> <hr/> See Figure 9 for additional NFPA 285 information.	<b>51</b>	<b>34</b>	<b>1-HOUR</b>
			

**Table 11 (Cont'd) - Assemblies With 5-1/2" accel-E® 38 Wall Panel**

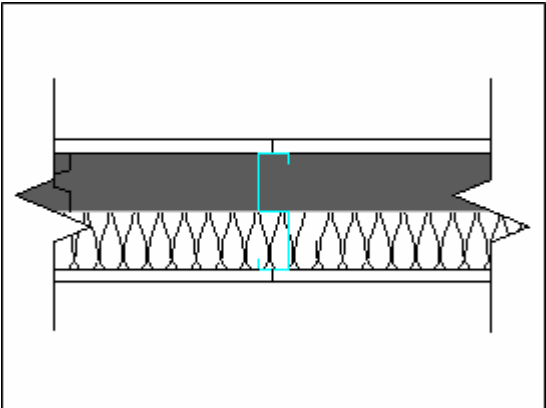
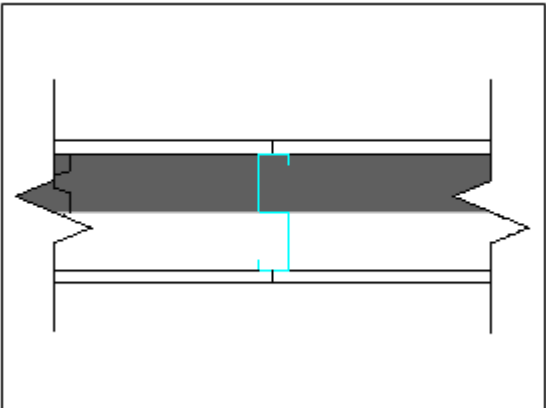
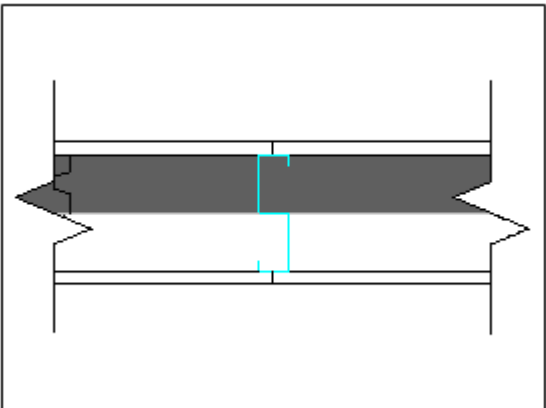
	Section STC	Section OITC	Fire Rating
	N/A	N/A	1-HOUR
<p><b><u>Non-Load Bearing</u></b></p> <ul style="list-style-type: none"> <li>▪ 5/8" Type X Gypsum Sheathing</li> <li>▪ 5-1/2" accel-E® Panel Studs @ 24" O/C</li> <li>▪ 3" Rockwool insulation 2.5 pcf density</li> <li>▪ 5/8" Type X Gypsum</li> </ul> <hr/> <p>See Figure 9 for additional NFPA 285 information.</p>			
	Section STC	Section OITC	Fire Rating
	N/A	30	1-HOUR
<p><b><u>Non-Load Bearing</u></b></p> <ul style="list-style-type: none"> <li>▪ 5/8" Type-X Gypsum Sheathing</li> <li>▪ 5-1/2" accel-E® Panel Studs @ 24" O/C</li> <li>▪ 5/8" Type X Gypsum</li> </ul> <p><b>Note:</b> Fire Rating is limited to fire exposure on the interior side</p> <hr/> <p>See Figure 9 for additional NFPA 285 information.</p>			
	Section STC	Section OITC	Fire Rating
	N/A	30	1-HOUR
<p><b><u>Non-Load Bearing</u></b></p> <ul style="list-style-type: none"> <li>▪ 5/8" Fiberglass Mats Exterior Gypsum Sheathing</li> <li>▪ 5-1/2" accel-E® Panel Studs @ 24" O/C</li> <li>▪ 5/8" Type-X Gypsum</li> </ul> <hr/> <p>See Figure 9 for additional NFPA 285 information.</p>			

**Table 11 (Cont'd) - Assemblies With 5-1/2" accel-E® 38 Wall Panel**

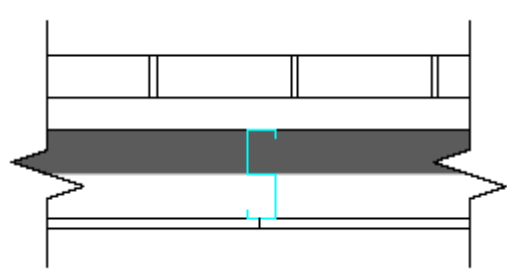
<b>Non-Load Bearing</b> <ul style="list-style-type: none"> <li>▪ 4" Nominal Clay Brick Veneer</li> <li>▪ 2" Maximum Air Gap</li> <li>▪ Dupont Tyvek Commercial Wrap</li> <li>▪ 5-1/2" accel-E® Panel Studs @ 24" O/C</li> <li>▪ 5/8" Type-X Gypsum</li> </ul> <hr/> <ul style="list-style-type: none"> <li>▪ Alternative Exterior Veneers:                             <ul style="list-style-type: none"> <li>○ 4" (min.) nominal concrete masonry units (CMU)</li> <li>○ 2" thick stone (slab-type veneer) with full mortared joints</li> <li>○ 7/8" Stucco – cement plaster and lath.</li> </ul> </li> </ul> <p>The water-resistive barrier shall not be asphalt or butyl-based membranes.</p> <hr/> See Figure 9 for additional NFPA 285 information.	Section STC	Section OITC	Fire Rating
	N/A	N/A	1-HOUR
			

**Table 12 - 8" accel-E® 38 & E54 S.T.E.P. Wall Assemblies**

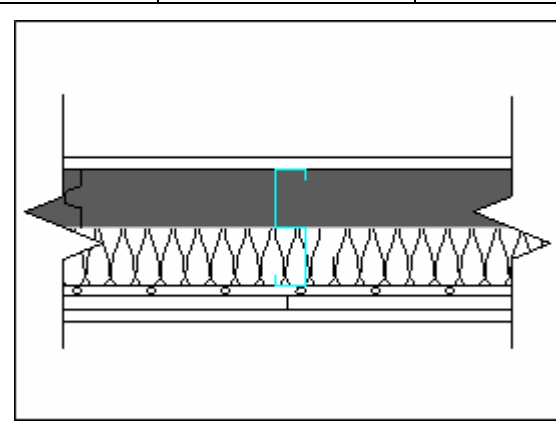
Assembly Description	Section STC	Section OITC	Fire Rating
<b>Non-Load Bearing</b> <ul style="list-style-type: none"> <li>▪ 5/8" Type-X Gypsum Sheathing</li> <li>▪ 8" accel-E® Panel Studs @ 24" O/C</li> <li>▪ 3-1/2" R13 Glass Fiber Insulation</li> <li>▪ 25 GA Resilient Channel spaced @ 24" O/C</li> <li>▪ (2) Layers 5/8" Type X Gypsum</li> </ul> <p><b>Note:</b> Fire rating is limited to fire exposure on the interior side</p> <hr/> See Figure 9 for additional NFPA 285 information.	<b>57</b> E38 Panel Only	<b>40</b> E38 Panel Only	<b>1 ½ HOUR</b>
			

**Table 12 (cont'd) - 8" accel-E® 38 & E54 S.T.E.P. Wall Assemblies**

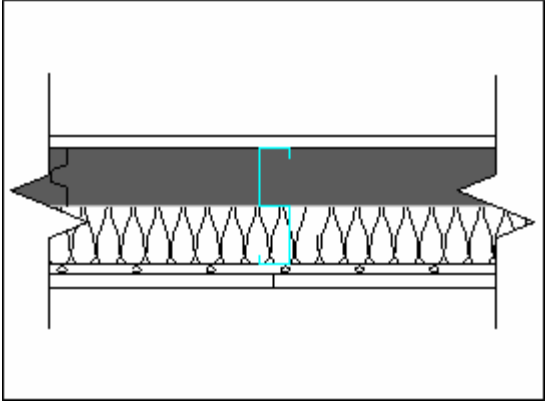
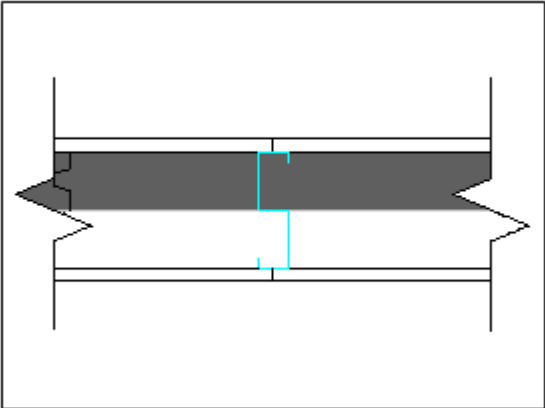
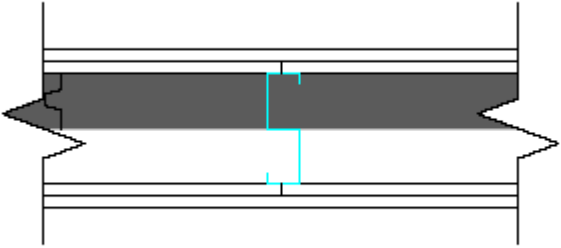
	Section STC	Section OITC	Fire Rating
	<b>54</b> E38 Panel Only	<b>36</b> E38 Panel Only	<b>1-HOUR</b>
<p><b><u>Non-Load Bearing</u></b></p> <ul style="list-style-type: none"> <li>▪ 5/8" Type-X Gypsum Sheathing</li> <li>▪ 8" accel-E® Panel Studs @ 24" O/C</li> <li>▪ 3-1/2" R13 Glass Fiber Insulation</li> <li>▪ 25 GA Resilient Channel spaced @ 24" O/C</li> <li>▪ 5/8" Type X Gypsum</li> </ul> <hr/> <p>See Figure 9 for additional NFPA 285 information.</p>			
	<b>N/A</b>	<b>N/A</b>	<b>1-HOUR</b>
<p><b><u>Load Bearing: (accel-E® 38 only)</u></b></p> <ul style="list-style-type: none"> <li>▪ 5/8" Fiberglass Mats Exterior Gypsum Sheathing</li> <li>▪ 8" accel-E® Panel Studs @ 24" O/C</li> <li>▪ Dietrich 5400 Modified Spazzer</li> <li>▪ 5/8" Georgia-Pacific Densarmor Plus(R)</li> </ul>			
	<b>N/A</b>	<b>N/A</b>	<b>2 HOUR</b>
<p><b><u>Non-Load Bearing</u></b></p> <ul style="list-style-type: none"> <li>▪ (2) Layers 5/8" Type "X" Gypsum</li> <li>▪ 8" accel-E® Panel Studs @ 24" O/C</li> <li>▪ (2) Layers 5/8" Type "X" Gypsum</li> </ul> <hr/> <p>See Figure 9 for additional NFPA 285 information.</p>			

**Table 12 (cont'd) - 8" accel-E® 38 & E54 S.T.E.P. Wall Assemblies**

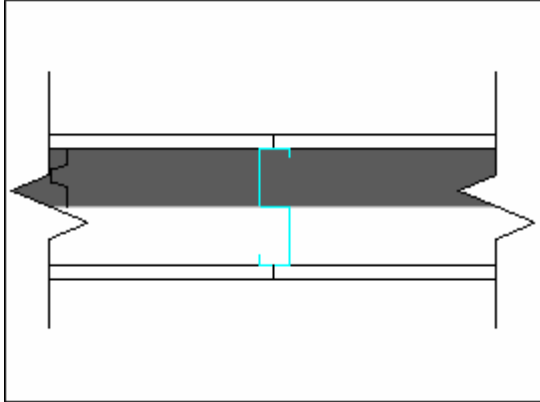
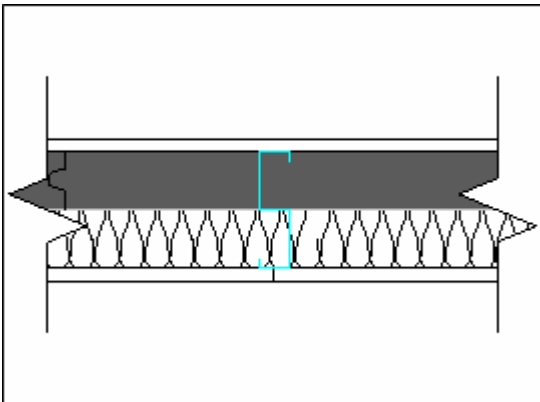
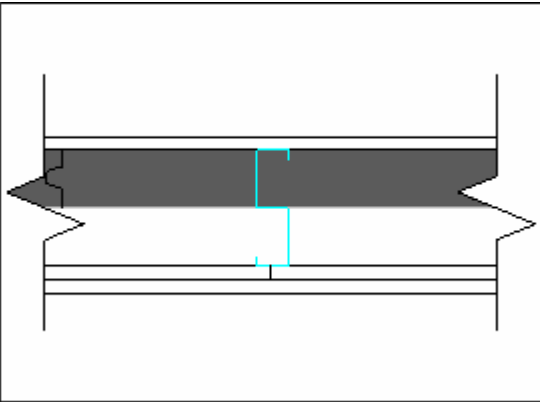
Assembly Description	Section STC	Section OITC	Fire Rating
<p><b>Non-Load Bearing</b></p> <ul style="list-style-type: none"> <li>▪ 5/8" Type-X Gypsum Sheathing</li> <li>▪ 8" accel-E® Panel Studs @ 24" O/C</li> <li>▪ 5/8" Type X Gypsum</li> </ul> <hr/> <p>See Figure 9 for additional NFPA 285 information.</p>	<b>45 (IRC Only)</b> E38 Panel Only	<b>31</b> E38 Panel Only	<b>1-HOUR</b>
			
<p><b>Non-Load Bearing</b></p> <ul style="list-style-type: none"> <li>▪ 5/8" Type X Gypsum</li> <li>▪ 8" accel-E® Panel Studs @ 24" O/C</li> <li>▪ 3" Rockwool insulation 2.5 pcf density</li> <li>▪ 5/8" Type X Gypsum</li> </ul> <hr/> <p>See Figure 9 for additional NFPA 285 information.</p>	<b>Section STC</b> N/A	<b>Section OITC</b> N/A	<b>Fire Rating</b> 1-HOUR
			
<p><b>Load Bearing: (accel-E® 38 only)</b></p> <ul style="list-style-type: none"> <li>▪ 5/8" Type X Gypsum</li> <li>▪ 8" accel-E® Panel Studs @ 24" O/C</li> <li>▪ Dietrich 5400 Spazzer</li> <li>▪ (2) Layers 5/8" Type X Gypsum</li> </ul> <p><b>Note:</b> Fire rating is limited to fire exposure on the interior side</p>	<b>Section STC</b> N/A	<b>Section OITC</b> N/A	<b>Fire Rating</b> 1-1/2 HOUR
			

**Table 12 (Cont'd) - Assemblies With 8" accel-E® 38 & E54 S.T.E.P. Wall Panel**

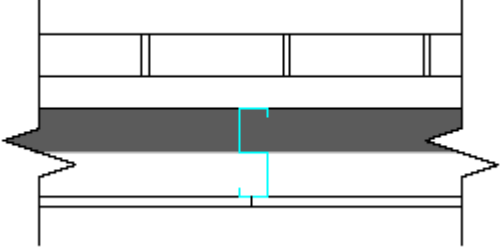
<b>Non-Load Bearing</b>	<b>Section STC</b>	<b>Section OITC</b>	<b>Fire Rating</b>
<ul style="list-style-type: none"> <li>▪ 4" Nominal Clay Brick Veneer</li> <li>▪ 2" Maximum Air Gap</li> <li>▪ Dupont Tyvek Commercial Wrap</li> <li>▪ 8" accel-E® Panel Studs @ 24" O/C</li> <li>▪ 5/8" Type-X Gypsum</li> </ul>	N/A	N/A	1-HOUR
<ul style="list-style-type: none"> <li>▪ <b>Alternative Exterior Veneers:</b> <ul style="list-style-type: none"> <li>○ 4" (min.) nominal concrete masonry units (CMU)</li> <li>○ 2" thick stone (slab-type veneer) with full mortared joints</li> <li>○ 7/8" Stucco – cement plaster and lath.</li> </ul> </li> </ul> <p>The water-resistive barrier shall not be asphalt or butyl-based membranes.</p>			
<p>See Figure 9 for additional NFPA 285 information.</p>			

**Table 13 – Thermal Properties**

1. Thermal Resistance (R-Value) IBC definition is the inverse of the time rate of heat flow through a body from one of its bounding surfaces to the other surface for a unit temperature difference between two surfaces under steady state condition per unit area. ( $\text{h} \cdot \text{ft}^2 \cdot ^\circ\text{F} / \text{BTU}$ )
2. Thermal Transmittance (U-Value) IBC definition is the coefficient of heat transmission (air to air) through a building component or assembly, equal to the time rate of heat flow per unit area and unit temperature difference between the warm side and cold side air films. ( $\text{BTU} / \text{h} \cdot \text{ft}^2 \cdot ^\circ\text{F}$ )

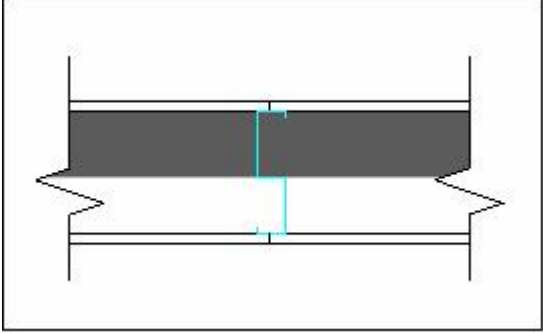
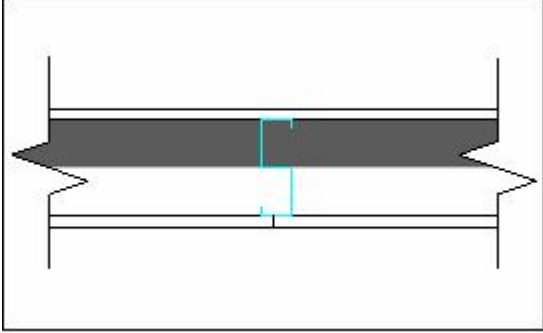
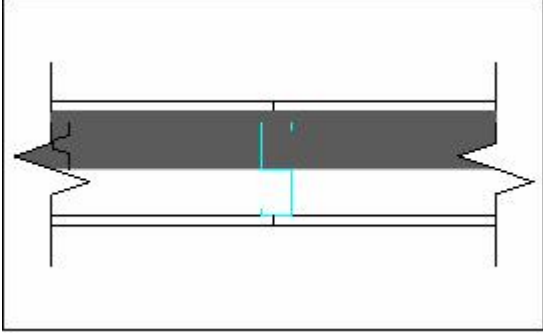
Assembly Description	Warm Side Air Temp.	Thermal Resistance (R-Value)	Thermal Transmittance (U-Value)
<ul style="list-style-type: none"> <li>▪ 8" accelE® Panel Studs @ 24" O/C</li> <li>▪ 7/16" Exterior OSB</li> <li>▪ Dietrich 5400 Modified Spazzer™</li> <li>▪ 1/2" Interior Gypsum Wall Board</li> </ul>	<b>21°C, 70°F</b>	<b>E38 = 17 E54 = 16</b>	<b>E38 = 0.051 E54 = 0.061</b>
			
<ul style="list-style-type: none"> <li>▪ 5-1/2" accel-E® Panel Studs @ 24" O/C</li> <li>▪ 7/16" Exterior OSB</li> <li>▪ Dietrich 5400 Modified Spazzer™</li> <li>▪ 1/2" Interior Gypsum Wall Board</li> </ul>	<b>Warm Side Air Temp.</b>	<b>Thermal Resistance (R-Value)</b>	<b>Thermal Transmittance (U-Value)</b>
	<b>21°C, 70°F</b>	<b>E38 = 11</b>	<b>E38 = 0.075</b>
			
<ul style="list-style-type: none"> <li>▪ 5-1/2" EXT accel-E® Panel Studs @ 24" O/C</li> <li>▪ 7/16" Exterior OSB</li> <li>▪ Dietrich 5400 Modified Spazzer™</li> <li>▪ 1/2" Interior Gypsum Wall Board</li> </ul>	<b>Warm Side Air Temp.</b>	<b>Thermal Resistance (R-Value)</b>	<b>Thermal Transmittance (U-Value)</b>
	<b>21°C, 70°F</b>	<b>E38 = 12</b>	<b>E38 = 0.067</b>
			

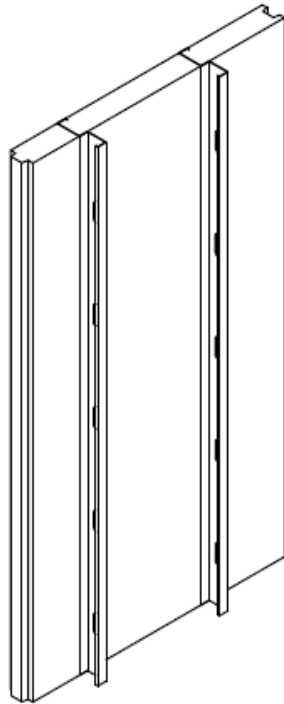

INTERIOR VIEW

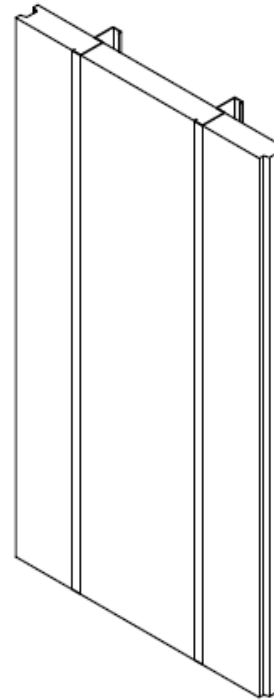

EXTERIOR VIEW

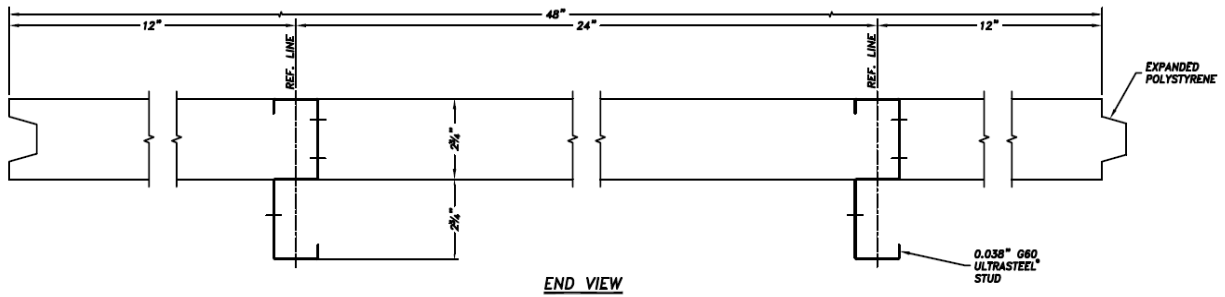

END VIEW

**Figure 1 – 5-1/2" accel-E® 38 Wall Panel**

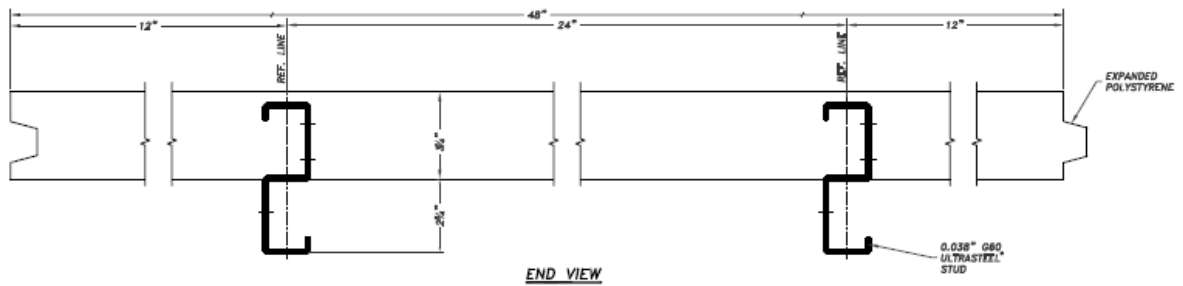
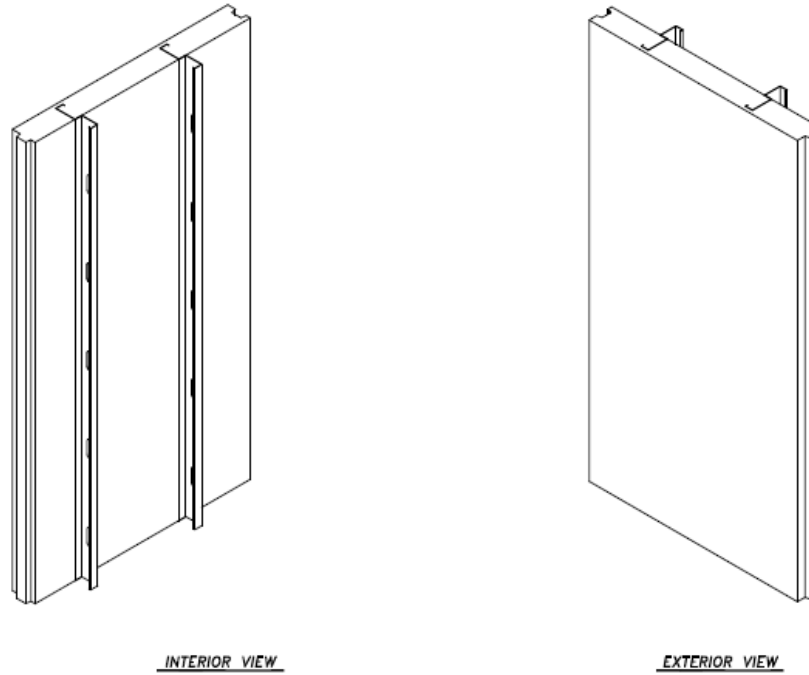
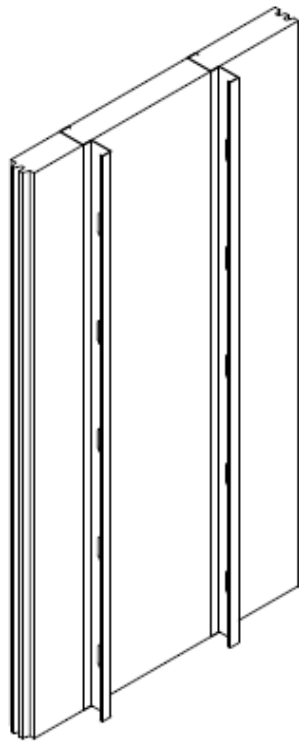
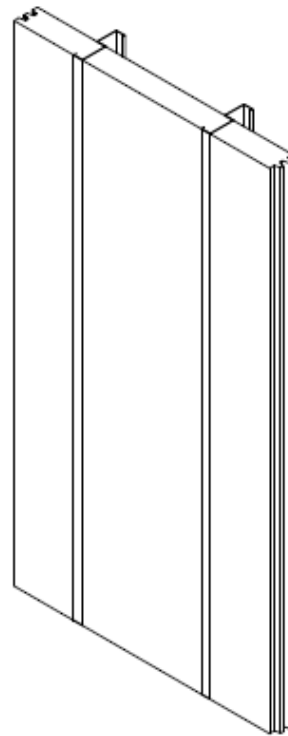

Figure 2 – 5-1/2" EXT accel-E® 38 Wall Panel



INTERIOR VIEW



EXTERIOR VIEW

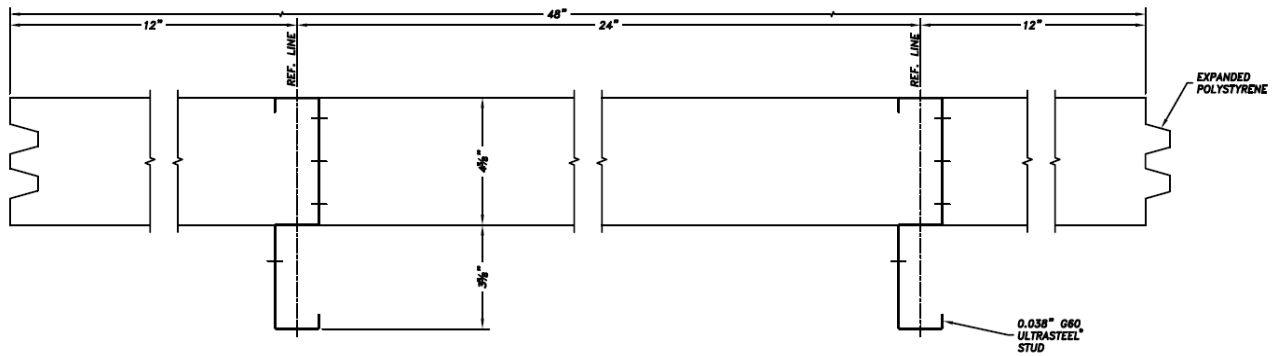

END VIEW

**Figure 3 – 8" accel-E® 38 Wall Panel w/double Tongue & Groove**

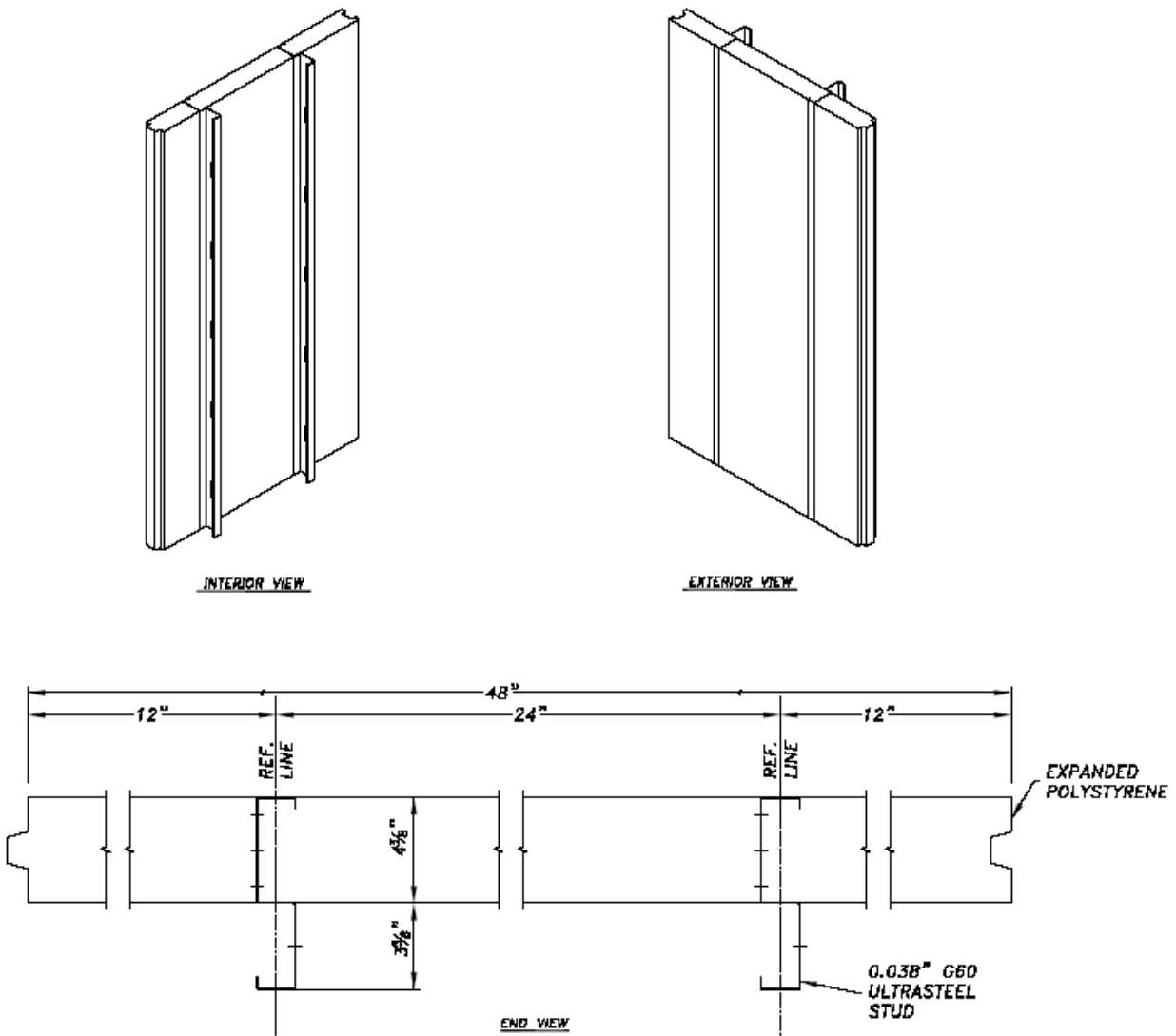

**Figure 4 – 8" accel-E® 38 Wall Panel w/single Tough & Groove**

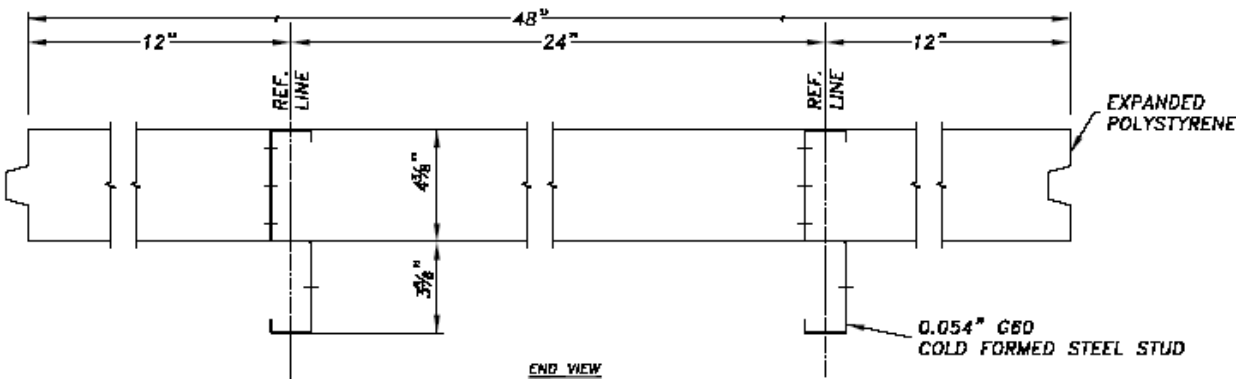
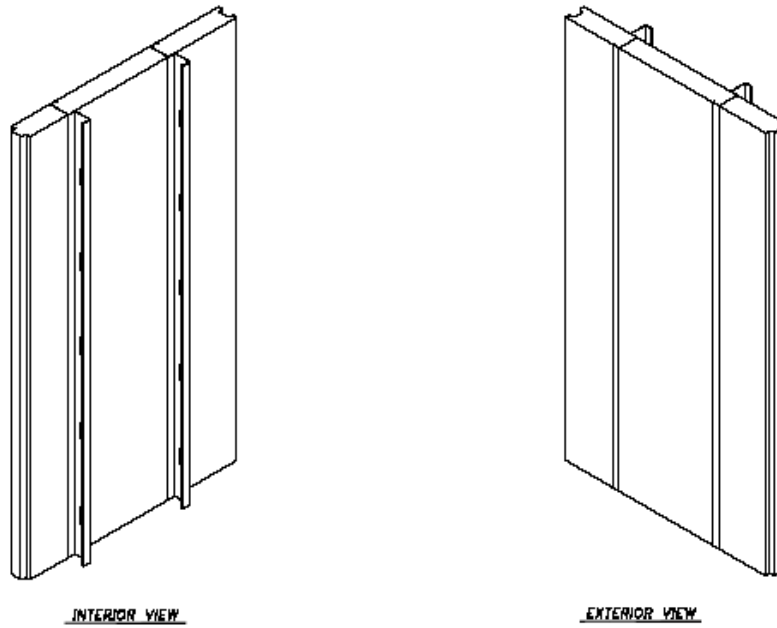

**Figure 5 – 8" accel-E® 54 Wall Panel**

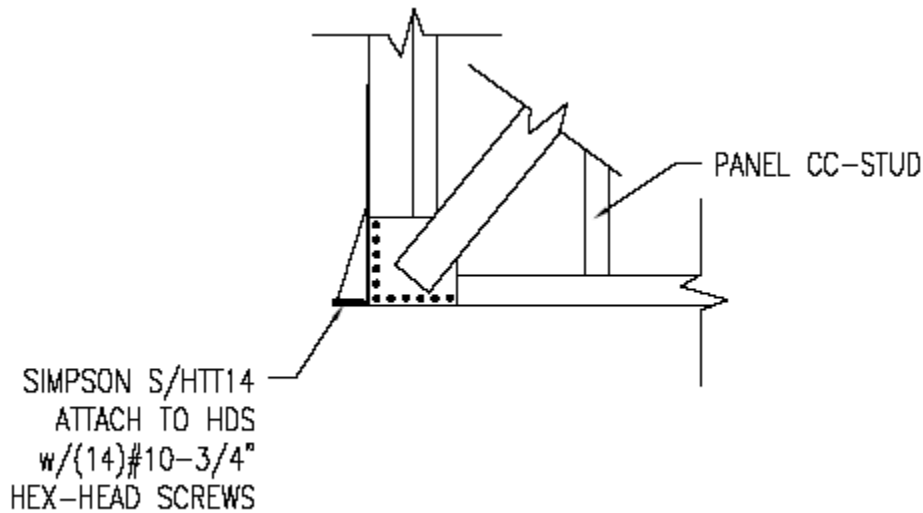
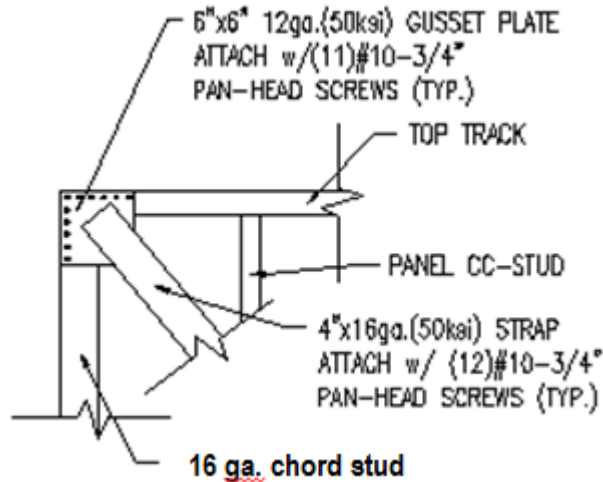
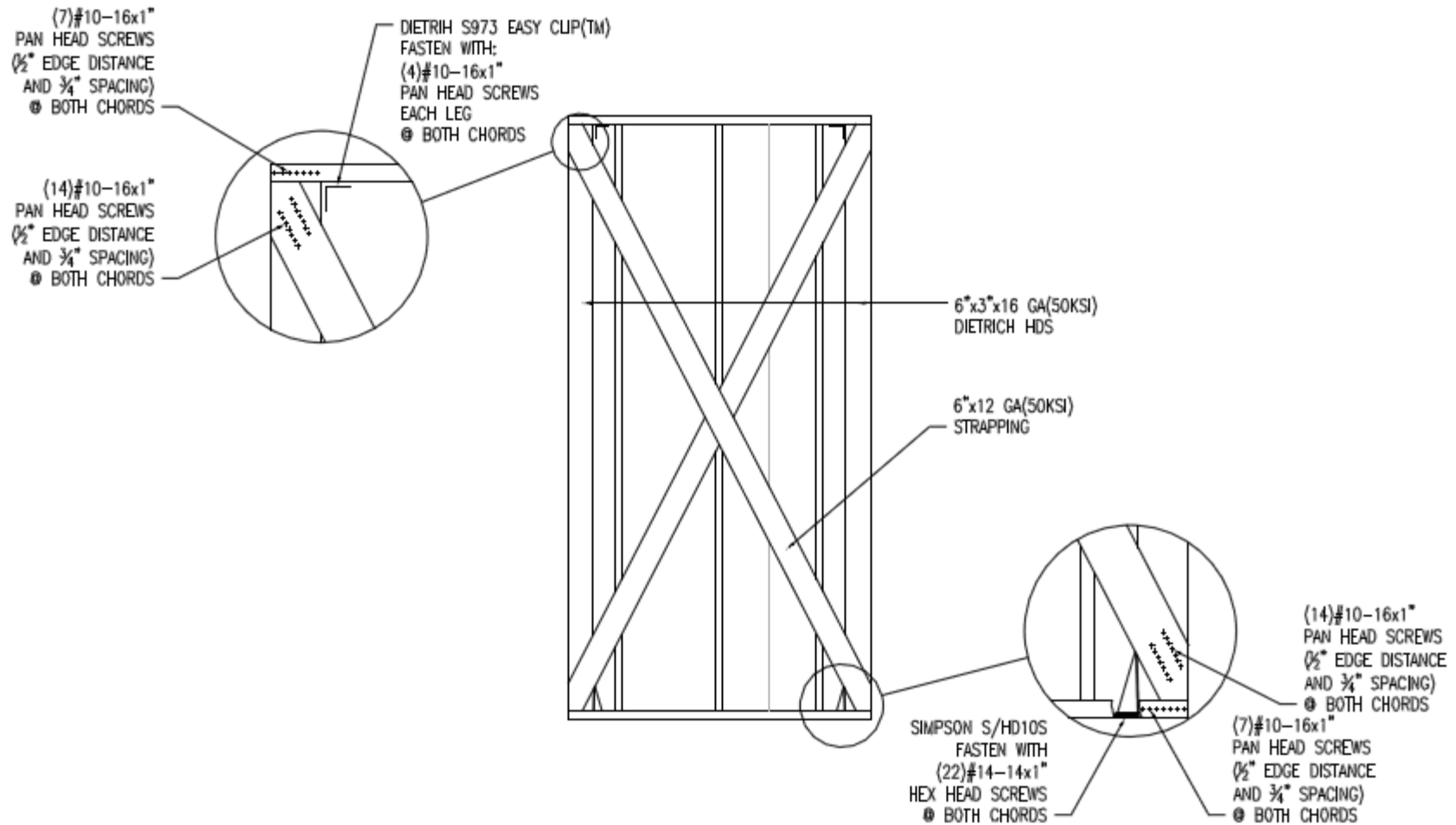
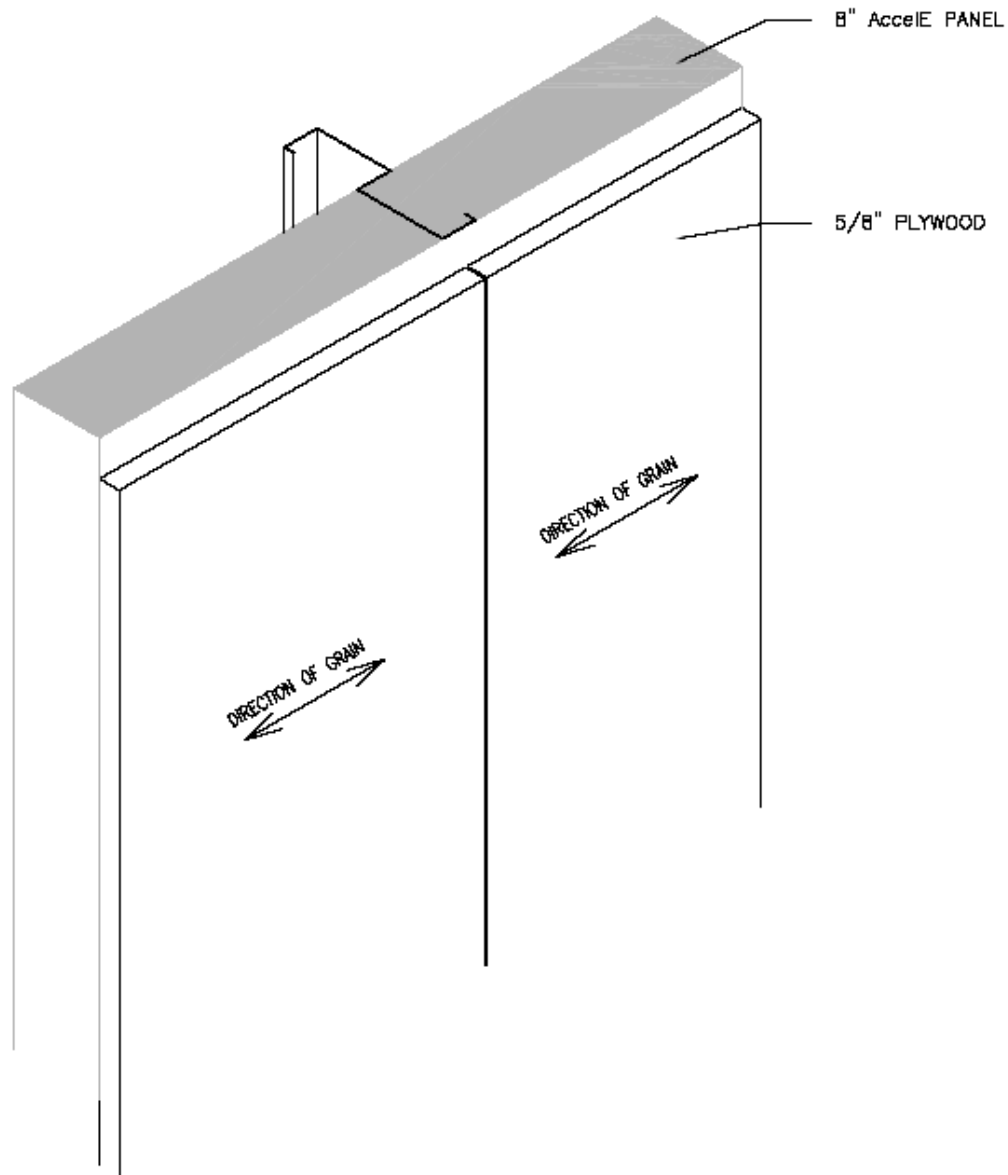
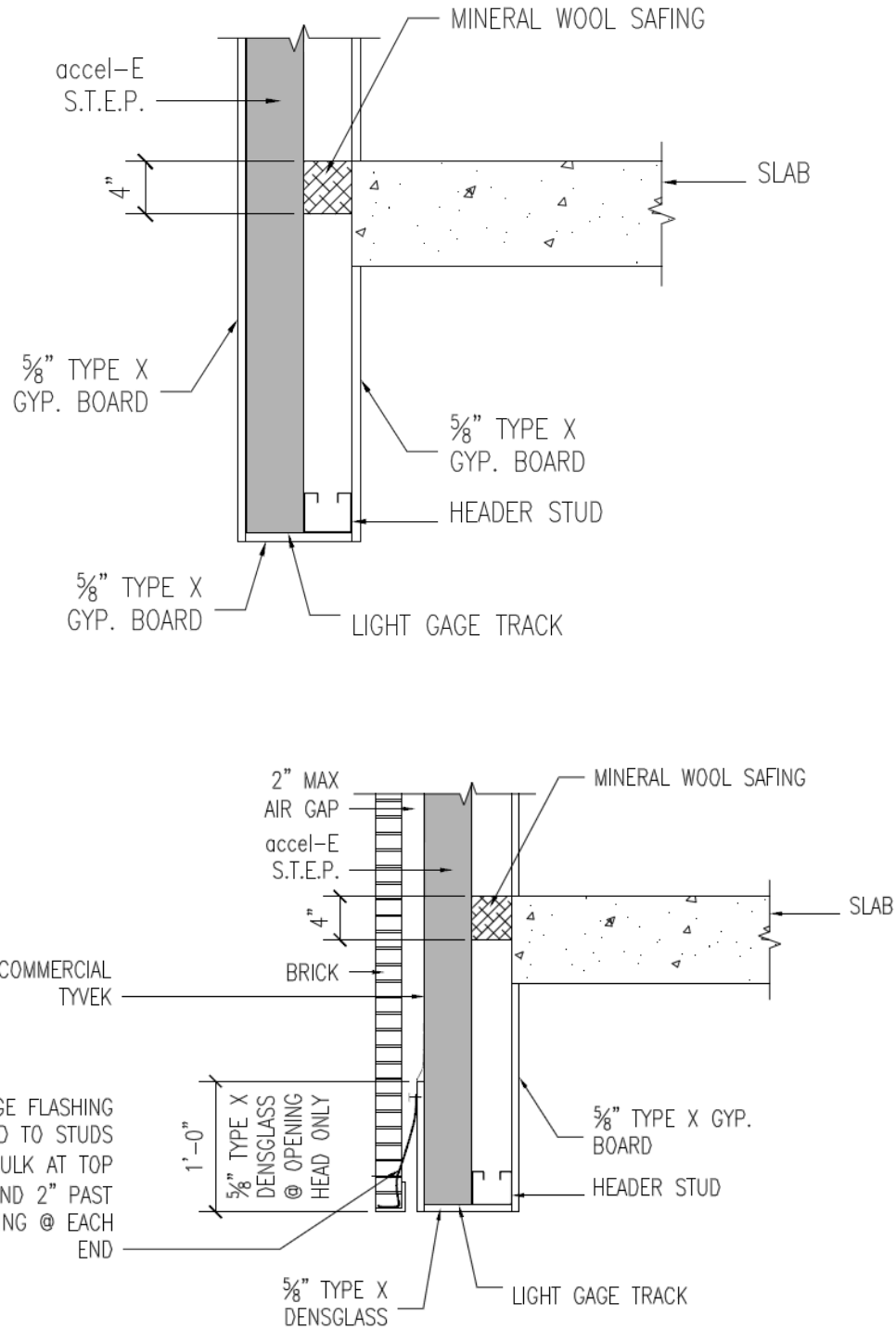

Figure 6 - X-Brace Gusset Plate w/Simpson Anchor for 5-1/2", 5 1/2" EXT & 8" accel-E<sub>38</sub> Wall Panel

**Figure 7 - X-Braced 8" accel-E@54 Wall Panel**



**Figure 8 –Wall System for FBC HVHZ Compliance**



**Figure 9 – NFPA 285 Details**